

Mini-Universal Hammock Frame — Instructions for use.

Congratulations! You have just purchased a Mini-Universal Hammock Frame designed and imported by The Hammock Company, Sydney, Australia. This frame is designed to suit most single and double Brazilian hammocks. It is not suitable for hammocks with a spreader bar. Now you can enjoy your hammock anywhere! There is a 12 month warranty on all materials and workmanship. Design registration pending.

Important

- Please ensure you read these instructions thoroughly before using this product.
- This is NOT a swing & children must be supervised at all times.
- Maximum load for this frame is 110Kg but only if the hammock is hung correctly (see fig 7).
- Do NOT hang hammock too high or the frame's weight capacity will be reduced (see how to attach your hammock step 3 & figure 6 & 7).
- Ensure that all wing nuts are securely tightened.
- Store in a dry place when not in use.
- Do not use if rust damaged (see Maintenance and Care section).

The Hammock Co.



Sydney, Australia

02 9560 0708

Parts of the Frame Your frame will contain the following items:

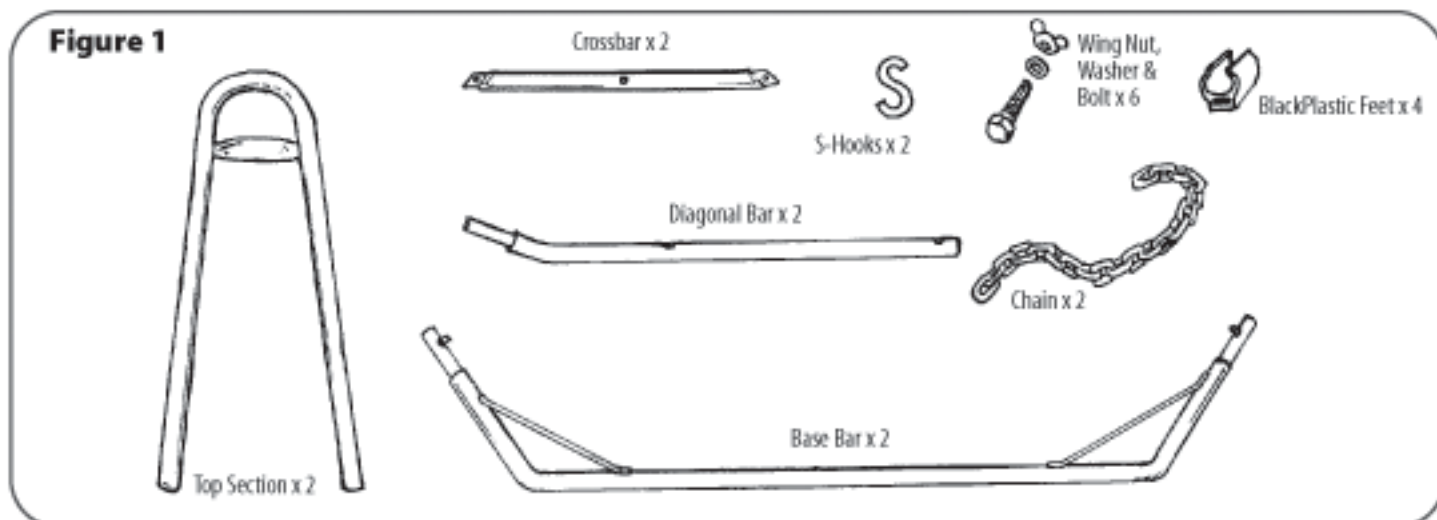

Assemble

Step 1) Assemble the two end sections:

Insert two diagonal bars into one of the top sections and align them as shown in figure 2. Secure them by bolting a cross bar behind the diagonal bars with two bolts, washers and wing nuts (figure 2 & 3). The cross bar should be attached with the angle cut at each end running in line with the diagonal bars to avoid sharp edges.

Attach chain to cross bar with third bolt, wing nut & washer (figure 3). Check all wing nuts are securely tightened. Repeat for second end section.

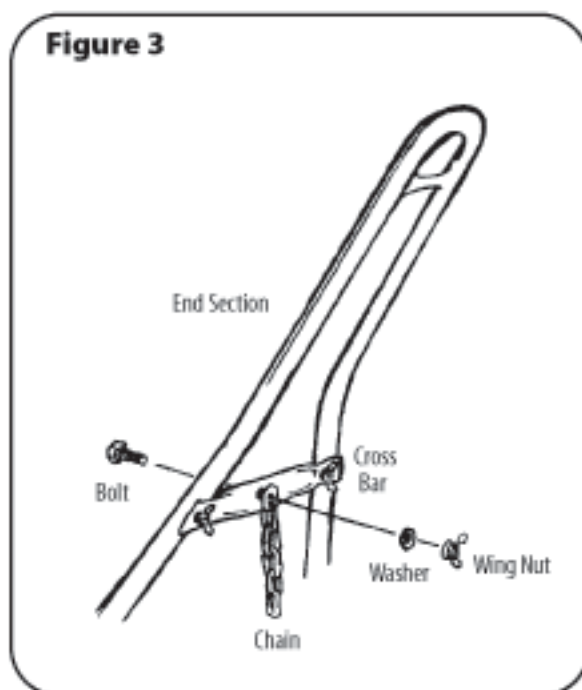
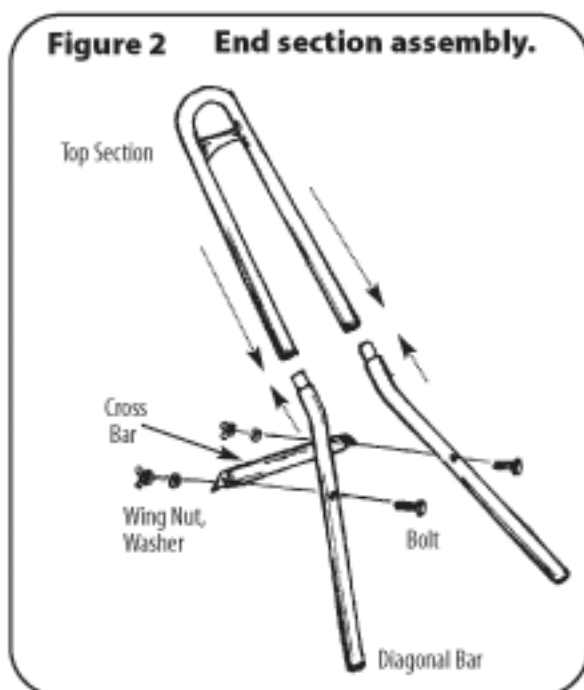

Step 2) Join the end sections with the base bars:

Insert the two base bars into the end sections (figure 4). Depress the silver safety clips on insertion and ensure that these clips then pop out through the holes in the diagonal bars and so secure the connection (figure 5). Finally, slot the 'feet' on the underside of the base bars (as shown in figure 5) by pressing the base bar firmly into the plastic foot.

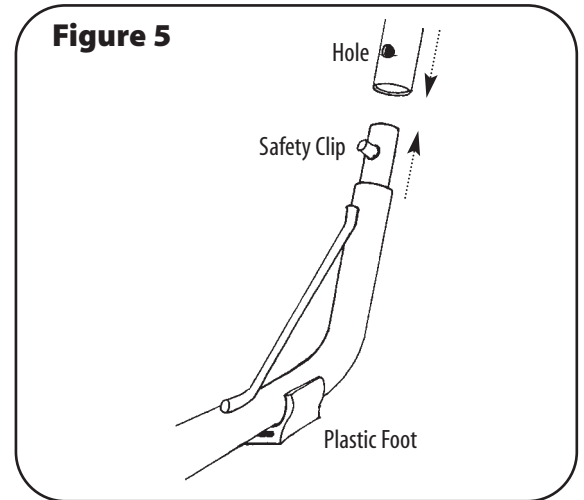
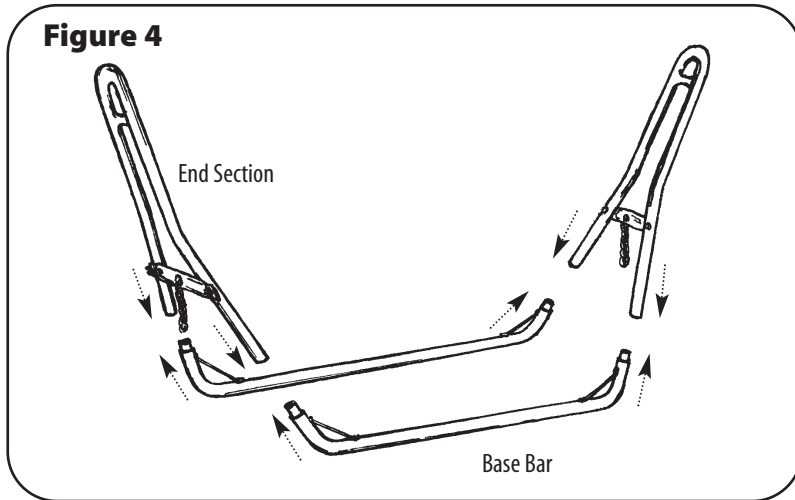

Step 3) Attach the hammock:

Pass the end of your hammock over the short bar of the top section and use the S-hook provided to hook it onto the chain (figure 6). (Make sure the strings of the hammock are not twisted before doing this). Repeat on the other side.

It is important that the centre of the hammock, when pressed down, is no more than 30cm from the ground (figure 7). Adjust the S-hooks up or down the chain on either side to ensure this. If your hammock is too long or too short to hang correctly, please call us for advice.

STORAGE: Remove hammock and disassemble base bars from end sections (leaving end sections intact).

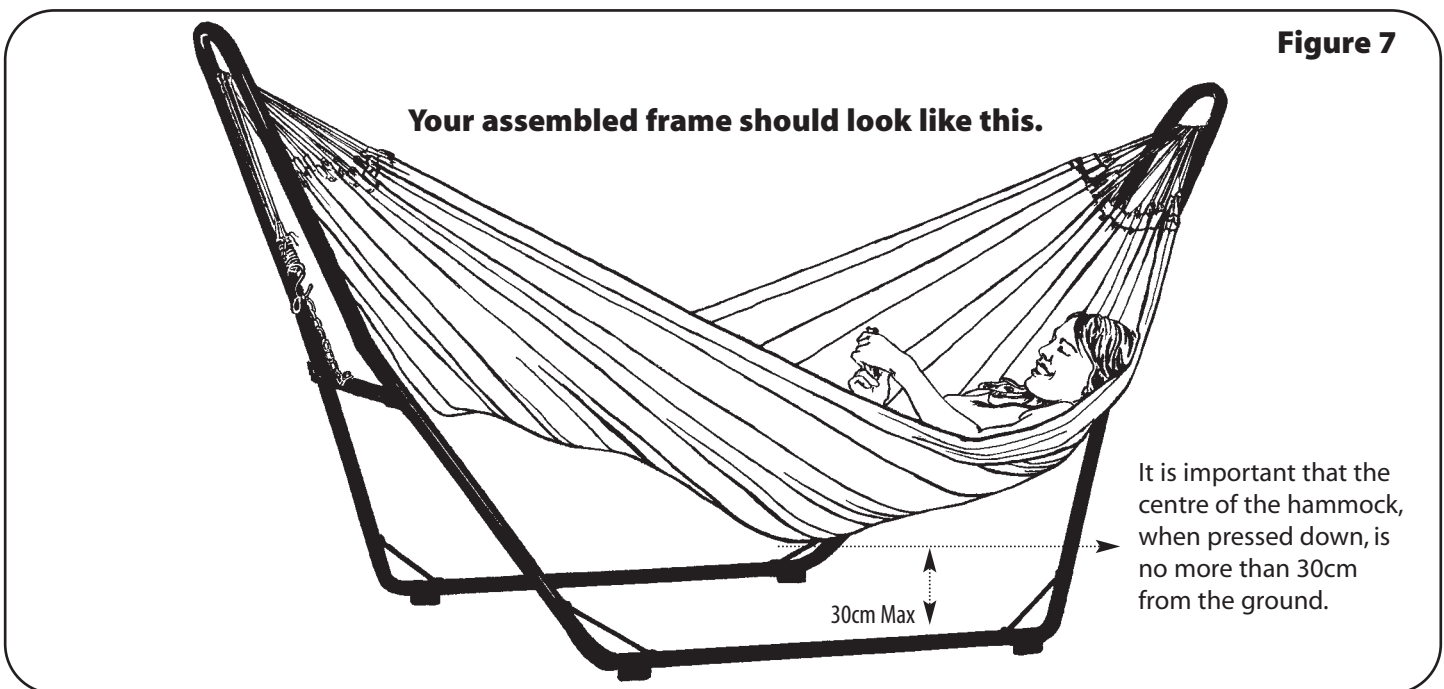
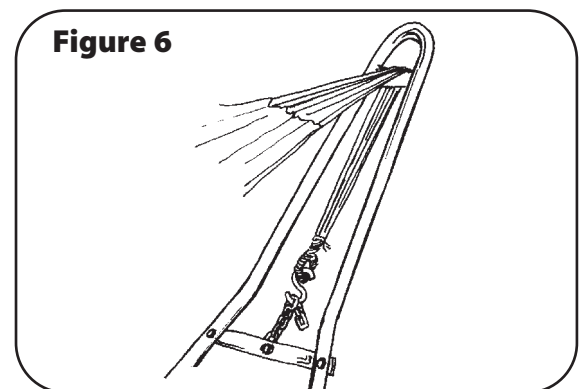

Maintenance & Care:

Your Hammock Frame is made of steel and will rust over time if left outside. The rust will occur on the insides of the tubes and on any areas where the paint is chipped. We strongly recommend that you store your frame in a dry place when not in use. Paint chips can be touched up with an oil based paint. There are also rust inhibitors that can be applied to the insides of the tubes; for around \$10-\$15, you can buy a 400g aerosol can of K&H "ARP" (anti-rust protection) available through Autobarn or Repco stores. This can be sprayed down both ends of each tube to give rust protection to the insides of the tubes. If you live near the ocean, salt in the air will accelerate the rusting process. We recommend an anti-rust protection spray **and** storing the frame in a dry place away from the salt air when not in use.

Inspecting for rust:

Look down the end of the tubes. A thin coating of brown powdery rust will not affect your frame but if the surface has become rough and pitted through rust damage, the frame's strength may be affected. If this is the case, do not use the frame and contact us for advice on (02) 9557 5074.